

Application : Copy Machine 、 Vending Machine 、 Massager

用途：影印機、自動販賣機、電動按摩器

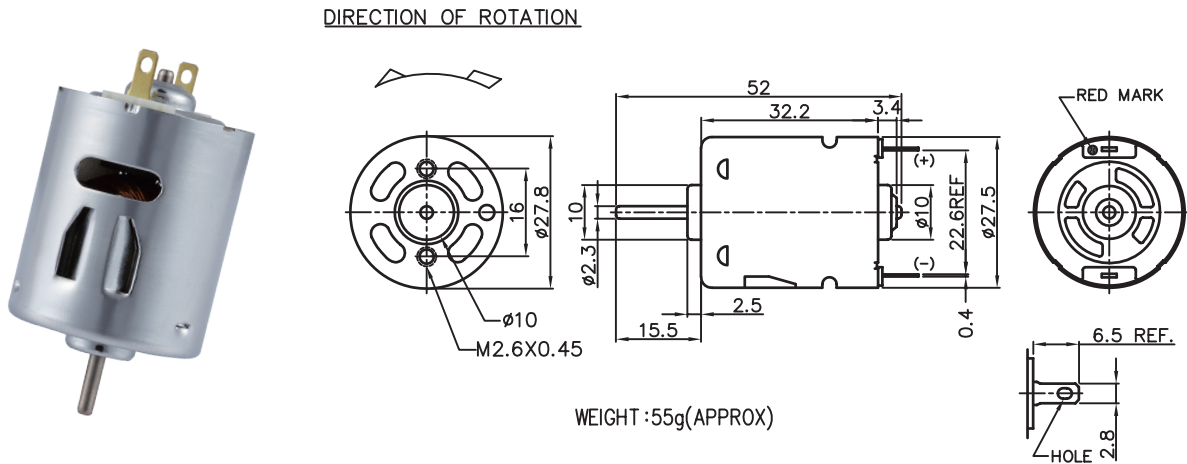

MODEL	VOLTAGE		NO LOAD		AT MAXIMUM EFFICIENCY					STALL			
	OPERATING RANGE	NOMINAL	SPEED rpm	CURRENT A	SPEED rpm	CURRENT A	TORQUE g-cm	OUTPUT mN-m	EFF %	CURRENT A	TORQUE g-cm		
MD3FN-3270	3.0 - 7.2	7.2V CONSTANT	14800	0.55	12200	2.10	75	7.35	9.32	61	10.40	440	43.14
MS3FN-18180	6.0 - 12.0	6.0V CONSTANT	4750	0.13	3700	0.42	36	3.53	1.38	59	1.60	173	16.96
MS3FN-19145	6.0 - 12.0	6.0V CONSTANT	5900	0.17	4300	0.59	40	3.92	1.81	53	2.01	172	16.86
MP3FN-2885	6.0 - 12.0	9.6V CONSTANT	15700	0.45	12900	2.40	106	10.39	14.22	62	11.05	600	58.82

馬達的出軸長度及性能參數，EMC 對策可依客人要求做調整，詳情可詢問相關業務人員。
Please inquire your sales representative for output, performance and EMC solution.

