

# PC-280

## Brush DC Motor

Application : Power-folding Rearview Mirror Actuator、Central Lock、Printer、Vending Machine、Beauty Equipment

用途：後視鏡電動收折、中控鎖、印表機、自動販賣機、美容儀器

### DIRECTION OF ROTATION

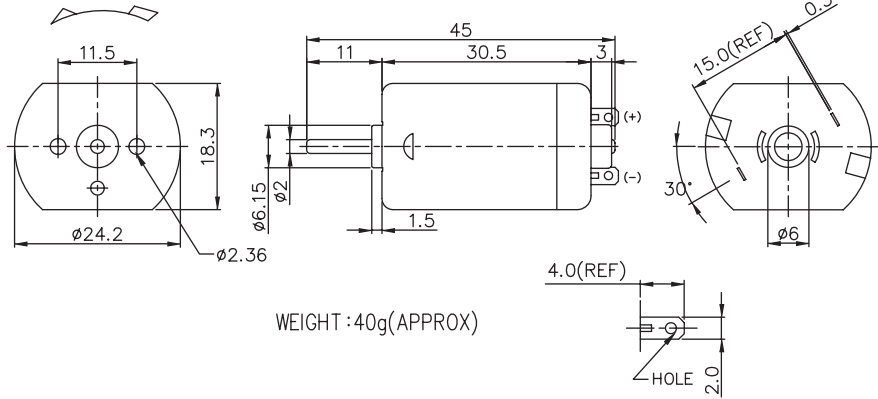

WEIGHT : 40g(APPROX)

MODEL	VOLTAGE		NO LOAD		AT MAXIMUM EFFICIENCY						STALL		
	OPERATING RANGE	NOMNAL	SPEED	CURRENT	SPEED	CURRENT	TORQUE		OUTPUT	EFF	CURRENT	TORQUE	
			rpm	A	rpm	A	g-cm	mN-m	W	%	A	g-cm	mN-m
PC-280S-3546P-R	3.0 - 4.5	3.6V CONSTANT	12000	0.48	10000	2.20	52	5.10	5.39	70	11.62	330	32.35
PC-280S-2663P-R	6.0 - 9.0	7.2V CONSTANT	17500	0.45	15129	1.33	41	4.02	6.36	68	8.15	311	30.49
PC-280P-12380-NR	12.0-24.0	24.0V CONSTANT	9500	0.06	7305	0.25	49	4.80	3.65	62	1.11	256	25.10
PC-280P-20150-NR	6.0 - 12.0	12.0V CONSTANT	12300	0.12	10300	0.72	53	5.20	5.64	66	3.86	334	32.75

馬達的出軸長度及性能參數，EMC 對策可依客人要求做調整，詳情可詢問相關業務人員。  
Please inquire your sales representative for output, performance and EMC solution.

